

**HZCT-IV**  
**Volt Ampere Characteristic Tester**

**User Manual**

Dear customer,

Thank you for choosing the device, please read the manual carefully. It will guide you to use the machine easily and skillfully.



Our aim is to improve the products with constant efforts, so there might be a little discrepancy exist between the real objects and the manual descriptions. We are really sorry for all the inconvenience it might cause and we'll inform you in the attached pages if any change is made. Please call our After-sale Service Department if you have any questions. It's our honor to be at your service.



Considering that the input/output terminals and the test column might be electrically charged, you should pay extra attention when you plug the wire and socket, for sparks may appear in the process. Please take care of personal safety in case of electric shock.

#### ◆Solemn Assurance

We provide free repair service if there is any quality defect within one year, dating from the day it is delivered. And we provide charged lifelong service after one year.

#### ◆Safety Requirements

Please read the following Safety Precautions carefully to avoid personal injury or damages to the machine itself and devices connecting to it. To avoid potential danger, this machine can only be used in specified regions.

Only qualified technicians are allowed to perform the repair.

**To avoid fires or personal injury, please.**

**Use proper power cord:** Only power cord that is special for the machine or of the right gauge can be used.

**Connect and disconnect correctly:** Please don't connect or disconnect the test wire if it is linked with charged terminals.

**Ground the machine.** The grounding column of the machine shell must be earthed, except when the product is earthed through the power ground wire. To avoid electric shock, grounding conductor must be connected to earth. You must make sure that the machine is correctly earthed before connecting the input or output terminals.

**Pay attention to the rated values of all the terminals.** To avoid fire and electric shock, please pay attention to all the rated values and marks. Before connecting, please read the User Manual for detailed information about the rated values.

**Don't operate without the cover.** If the cover is removed, please don't operate the machine.

**Use proper fuse.** Only fuse that is of the right gauge and right rated value can be used.

**Avoid contact with exposed circuit or charged metal.** If the machine is charged, please don't touch the exposed parts.

**If there are potential bugs, stop the operation.** If you suspect there is any damage, please call our staff for examination. And stop operating the machine right away.

**Please don't operate the machine in humid and explosive environment.**

**Make sure that the machine surface is clean and dry.**

### **Safety Terms**

**Warnings:** Warnings point out dangerous practice or situations which might cause death and injuries.

**Caution:** Cautions point out practice or situations that might cause damage to the machine or other property.

## **Contents**

I. Summary.....	1
II. Technical Parameters And Hardware Structure.....	4
III. Operation Method.....	6
IV. Fault Maintenance.....	42
V. Scroll Printer Installation.....	43
VI. Common Fault Handling And Usage.....	43
VII. Packing List.....	44

## I. Summary

The device is a new generation of innovative CT, PT test instrument which is launched market after a lot of market research and through the identification of strict professional testing and certification authorities. Device adopts high performance processor and microcomputer control architecture, the advanced manufacturing technology ,which ensure the stable and reliable product performance, complete functions, high degree of automation, high testing efficiency. It is in leading level in the domestic and the professional testing equipment of relay protection and high voltage insulation industry to test the current transformer and voltage transformer. Transformer volt ampere characteristics comprehensive test instrument is a fully automated PT, CT testing instrument, the instrument can accomplish test which include CT & PT volt ampere characteristic of test, CT& PT polar polarity test, CT & PT ratio and polarity ratio and polarity test, automatic calculation of arbitrary point CT error curve, CT/PT ratio than the poor results of parameters. The instrument can automatically collect, analyze, store and print the test data, and it can also be stored by the U disk. In addition, the monitor uses 8 inch color large screen, high resolution 800\*600, full touch operation, real-time display test curve, observe test case immediately, so that the test personnel to judge the failure of the test. Test report not only tell the fine test curve, but also listed test data in accordance with the arrangement of the preferred number, and indicate the test time and print time, so can be used as the original test data. This product is suitable for the field test and calibration of all kinds of CT and PT because of its large output capacity and full function.

### **Main technical features:**

#### **1、 Full Automatic Test Instrument**

Simply set the highest output voltage and the maximum output current, the instrument can start from zero to automatically boost or rise for a variety of tests. The test data, the curve of the volt ampere characteristic curve, the 10% and the 5% error curve are recorded automatically, and the turning point value is calculated automatically. Eliminating manual voltage regulator, manual record sorting, tracing curves and so on cumbersome step , greatly improves the efficiency of the test. The test results can be

stored in the computer, can print on spot and after printing, can also use U disk copy to computer printing processing. The operation is fast, simple, convenient and easy to grasp.

## **2、 Full Function**

The functions provided by the device are as follows:

### **CT test:** Volt ampere characteristic curve

- Automatic calculation of curve inflection point

- 5% and 10% error curve

- Ratio and polarity

- Differential and angular error measurement

- Secondary side circuit load testing

- Secondary winding ac withstand voltage

- The second dc resistance test

- A flow test

### **PT test:** Volt ampere characteristic curve

- Automatic calculation of curve inflection point

- 5% and 10% error curve

- Ratio and polarity

- Difference, angular difference measurement

- Secondary side circuit load testing

- Secondary winding ac withstand voltage

- The second dc resistance test

## **3、 Output Keeping**

Keeping boost function, used to measurement and detection and Secondary ac withstand voltage test. Keeping upwelling for the secondary loop check

## **4、 True Effective Value Sampling**

All voltage and current signals are true and valid values sampling, please use the true effective value of the table to correct.

## **5、 Single Power Supply, Easy To Operate**

Only need a single input power supply, AC220V, abandon the backward means of which the individual manufacturers still need 380V power to achieve the technical requirements.

## **6、 U Disk Save**

The test data can be transmitted to the PC through the U disk, processed, displayed, printed and storage of data and curves by PC, which greatly facilitates the user report.

## **7、 Date And Clock**

Instrument comes with the system time, device automatically records the test time during test, in order to store test records and view.

## **8、 No Contact Test, High Security**

Fully computerized device, without manual contact after setting, the instrument fully automatic test which enable the test personnel to be far away from the high voltage circuit, to ensure the test personnel security.

## **9、 Large Output Capacity**

Single output power, AC voltage output up to 2000V, current output short time up to 25A; maximum current 600A.

## **10、 With Large 8 Inch Color Touch Screen LCD**

Screen resolution ration up to 800\*600, high definition, full color touch operation leading domestic, interface background dream, the test directly shows the volt ampere curve, test record data, intuitive and convenient. The panel comes with a printer, can be printed at any time curve and test data.

## **11、 Touch Screen Operation**

Using the original touch technology of our company to operate. Full cancellation of the panel buttons, switches, control knob and other conventional controls. The operation is simple and convenient, and the service life is long.

## **12、 Ultra Large Capacity Data Storage**

Each function test can store 50 groups of test data, data power loss will not be lost forever, after test it can be printed through loading or upload to the computer to save, print. Instrument also has a single U disk data storage function, the field test data is saved to the U disk, so that the field test records unlimited storage.

## II. Technical Parameters And Hardware Structure

### 1、 Technical Parameters

Power input voltage		AC 220V AC 220 V	Resolution ratio
CT volt ampere characteristic test	Secondary current secondary voltage	0~2500 V, 0~20A	1mV、 1mA
CT variable ratio error, angle error test	Primary side current	<b>0~1000A</b>	1mA
	Secondary side current	0~5 A	1mA
CT secondary loop load	Secondary side current	0~5 A	1mA
	Secondary-circuit	0~10Ω	0.001Ω
CT primary flow	Primary side current	0-1000A	1mA
PT Volt-ampere characteristic test	Output voltage	0~200 V	1mV
	Output current	0~10 A	1mA
PT variable ratio, ratio angle error test	Primary side voltage	<b>0~2500 V</b>	1mV
	Secondary rated voltage	100V,57.7V,1 50V	1mV
Accuracy class	Volt ampere characteristic	< 0.5%	
	5% and 10% error curve	< 1%	
	Ratio test	< 0.5%	
	Angle error test	< 1%	
	Secondary loop load test	< 0.5%	
Power supply voltage		AC 220 V 50~60 Hz	
Working environment temperature		-10℃ – +50℃	

### 2、 Basic Structure And Composition

The host device includes automatic booster, Built-in flow device, microcomputer control system and 8 inch color screen in Chinese LCD, resolution ration up to 800X600, with a micro printer, touch operation, USB connection, etc.. The host device can be directly used for volt ampere characteristic the test and inflection point calculation of CT, the 5% and 10% error curve, variable ratio polarity test, Contrast test, angle difference test, Secondary side circuit load testing, a flow-through test. volt ampere characteristic test and variable ratio polarity test of PT and Secondary

winding ac withstand voltage of CT &PT, The second dc resistance test, etc.

### 3、Panel Structure Description

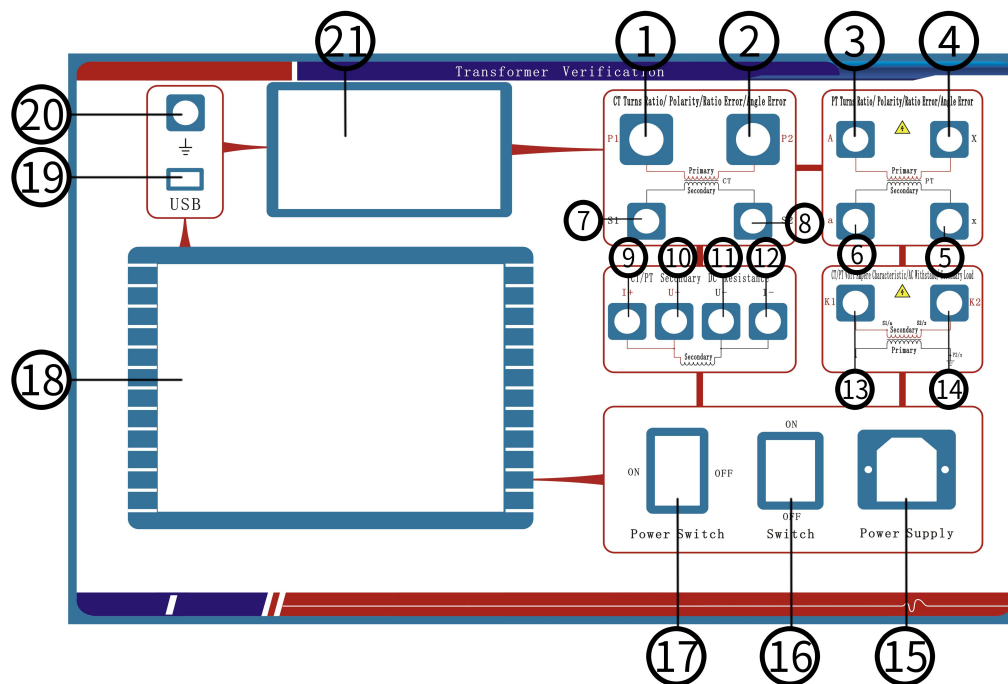

Figure 1

1. Current transformer A P1 (Polar end)
2. Current transformer A P2 (non-polar end)
3. Voltage transformer a high end (pole)
4. Voltage transformer secondary high end (pole)
5. Voltage transformer secondary low end(non polar end)
6. Voltage transformer a low end (non polar end)
7. Current transformer secondary S2 (non polar end)
8. Current transformer secondary S1 (pole)
9. DC resistance I+ interface
10. DC resistance test U+ interface
11. DC resistance test U- interface
12. DC resistance test I- interface
13. Volt ampere characteristic test, Ac withstand voltage, the secondary load test K1
14. volt ampere characteristic test, Ac withstand voltage, the secondary load test k2
15. Device power input socket

16. device. Switch
17. The power switch of device
18. Insurance 1( control power insurance (2A))
19. USB interface
20. Grounding
21. Printer

***Each terminal edge has a clear character identification, do not make wrong as test connection to avoid causing damage to the equipment!***

### **III. Operation Method**

#### **1、 Touch Screen Using Method**

Touch screen function similar to the touch screen of mobile phones, you click the corresponding icon or text with the finger directly when need to perform a certain operation or instructions.

**Data input:** When you need to modify the data, please use the finger directly click the data which need to be modified, click the touch screen, then pop up the virtual keyboard, directly click the data which needs to be inputed, certain keyboard for the virtual keyboard is to determine the current input. The return arrow is to delete the current input data and the key cancel is to cancel all the data that is currently being entered.

#### **2、 Main Menu**

Connected to the AC power supply AC220V on panel, open the power switch on the control panel, color LCD screen back light, the device for self inspection, after the test is completed, will enter the main menu, as shown in Figure 2.

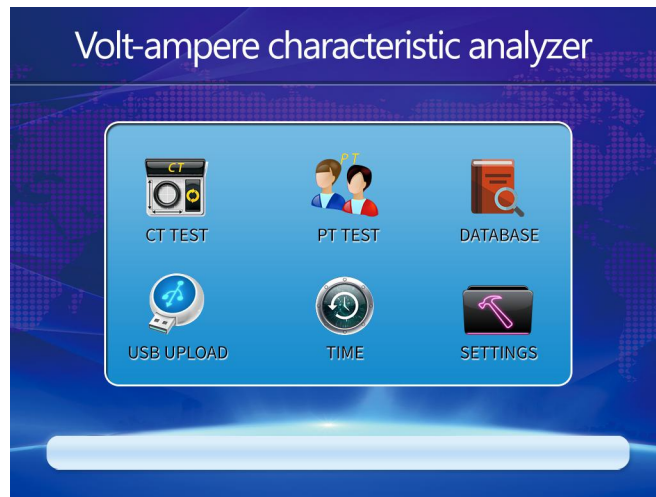

Figure 2

Main menu has 6 options, it is CT test, PT test, data query, U disk to save, clock settings, factory settings.

CT test: including CT volt-ampere characteristic test , CT variable ratio polarity test, CT ratio difference angle difference testing, CT secondary load testing, CT secondary DC resistance test,CT AC withstand voltage test ,CT a flow through test , a total of 7 test functions.

PT test: including PT Volt-ampere characteristic test, PT ratio and polarity test, PT ratio difference angle difference testing, PT secondary load testing, PT secondary DC resistance test, PT ac withstand voltage test, a total of 6 functions.

Data query: all the test data are stored in the data query.

U disk to save: all the data to be imported into the U disk.

Clock settings: if the current time is not accurate, you can enter the clock settings to adjust.

Factory setting: used for manufacturers to carry out the relevant parameters of the setting and debugging, not open to users.

### 3、CT Volt Ampere Characteristic Test

**Test Objective:** To check the quality of the iron core of the transformer, calculate the 10% error curve by identifying the saturation degree of the magnetization curve, and use it to judge whether the secondary winding of the transformer has turn to turn short circuit.

In the main menu interface, click on CT testing options, select the menu for CT test

content (Figure 3), move the cursor to someone, press the rotary mouse then goes into test interface. After the operation is completed, press return, then can be out of interface.

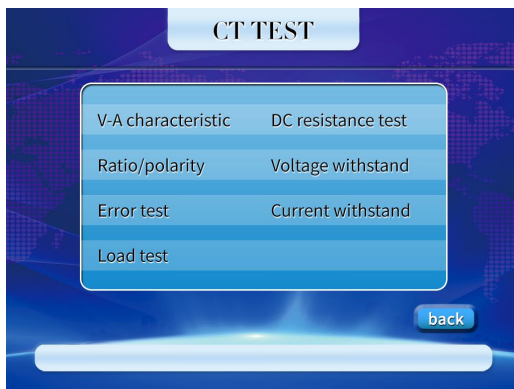

Figure 3

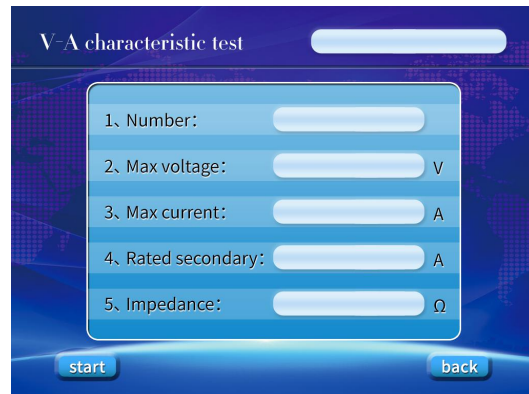

Figure 4

(1) Software interface of CT volt ampere characteristic test

On the CT test main interface, move the cursor to the "CT volt ampere characteristics test" option, the finger click to enter the CT volt ampere characteristics test setup interface, as shown in Figure 4.

Interface parameter description:

Transformer number: The current test transformer input a unique number for the distinction.

The maximum output voltage: the maximum voltage which secondary side current transformer can bear, the booster output voltage range of 0-2500V.

Maximum output current: maximum current which secondary side current transformer can bear, booster current range is 0 ~ 25 A.

CT rated secondary current: current current transformer secondary rated current, generally 5A or 1A.

CT secondary impedance: the secondary impedance value of the transformer, if you do not know , it can be used to test by the DC resistance function, or enter a numerical value of less than 1 ohm.

Start test: press this key to start, then enter into the CT volt a mpere characteristic test interface.

Return: press this key to return to the first level test interface.

**Note: Parameter setting**

The maximum output current: setting range (0-25A) for the highest setting current of the instrument output, if the current in the experiment reach the set value, it will automatically stop the flow, so as not to damage the equipment. According to the experience , measuring current transformer current setting value is greater than or equal to 1A, you can test the value of the inflection point. Protection level current transformer current is usually set greater than or equal to 3A, can also be tested to the inflection point

The maximum output voltage: setting range (0-2500V) is the highest setting voltage of instrument output, usually voltage settled slightly higher than the inflection point voltage, which makes the ratio of curve more coordinated, if the voltage is set too high, curve is close to the Y axis (the voltage coordinate), if voltage is set too low, curve is close to the X axis (current value coordinates). If the voltage in the experiment reaches the set value, it will automatically stop the boosting, so as not to damage the equipment. According to the empirical, measurement of the current transformer voltage settings are mostly in the 50V and below the 50v, then can test the inflection point, the protection level of the current transformer voltage set a little high, it also can test inflection point during 100v.

If the transformer inflection point is unknown then according to the experience may set an voltage (usually transformer ratio greater the inflection point voltage higher). Such as setting 200V test, if the curve is very close to the X axis, we can reduce set voltage to 100V according to the inflection point; if the curve does not reach the inflection point, namely voltage at or close to the set value 400V when the current is only several or dozens of Ma, then the voltage is too low, The rise of corresponding set voltage can make the volt-ampere characteristic curve.

According to the experience , generally small ratio the current transformer such as 500/5, the voltage set within 50V, current setting around 2A can test inflection point, if increasing voltage, it will cause the curve is very close to the X axis (current value coordinates).

## **(2) Operation instructions for the CT volt ampere characteristic test**

Confirm the right connection, the first go through to the main circuit output control switch, set the maximum output voltage, the maximum output current and other parameters, with a finger click the start option on the bottom of left side, you can start the

test.

①Test

**Test connection**

Use the device to test the schematic wiring diagram, as shown in Figure 5.

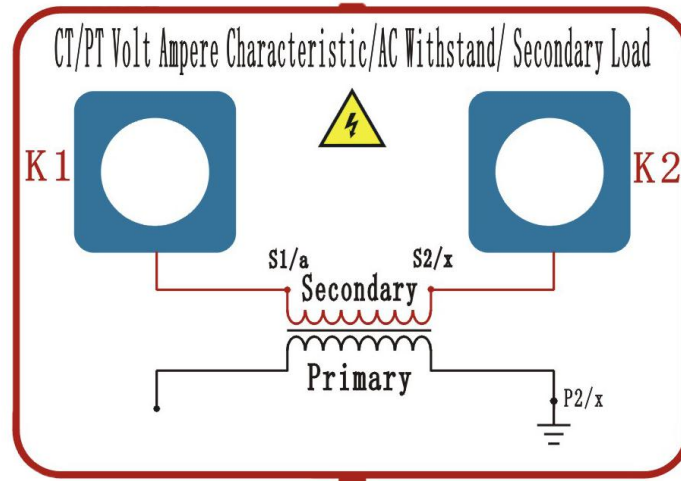

Figure 5

**Note 1:** CT volt ampere characteristics test, on the device the other terminals do not do wiring, and the volt ampere characteristics test Of current transformer , only for the relay protection requirements of the secondary winding .

**Note 2:** CT volt ampere characteristic test, we should make test CT secondary winding wires are disconnected from the original and can not be grounded, and disconnected the other secondary winding.

**Note 3:** If making CT volt ampere characteristic test continuously for a long time, should have a rest and cooling for a certain time, so as not to burn it in the condition device is too hot.

**Note 4:** Measured volt ampere characteristic curve is compared with that of the past or ex factory, and the voltage should not be reduced obviously. If there is a significant reduction, it should be checked whether there is a turn to turn short circuit between the secondary windings. When there is an inter turn short circuit, the first part of the curve current is slightly lower than the normal part of the current.

**Test method**

According to the test wiring diagram, confirm the right wiring, connect the main circuit

output control switch, set the parameters in CT volt ampere characteristics test interface, click start, enter CT volt ampere characteristic test curve interface, as shown in figure 6.

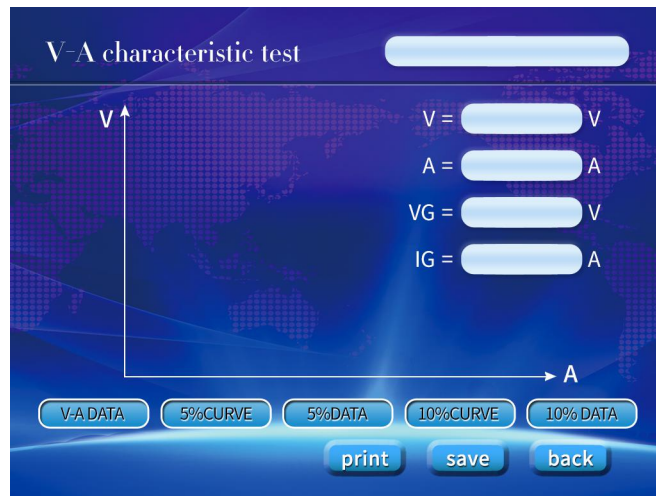

Figure 6

The device gradually increase the voltage and current to test automatically according to the set voltage and current , in the process of testing each a point measured automatically is recorded in the error data , and show recorded the current voltage value, current value parameter

During the test, on the upper right corner of the screen, the V and I real-time display current and voltage current value, the white box of the right corner is the status bar of equipment, real-time tracking and display equipment action and state, if stop the experiment in the artificial test process, click the back button to return to suspend the test automatically.

②Test results operation instructions

After the test, the screen shows the CT volt ampere characteristic test curve (shown in Figure 7). The interface operation functions are as follows:

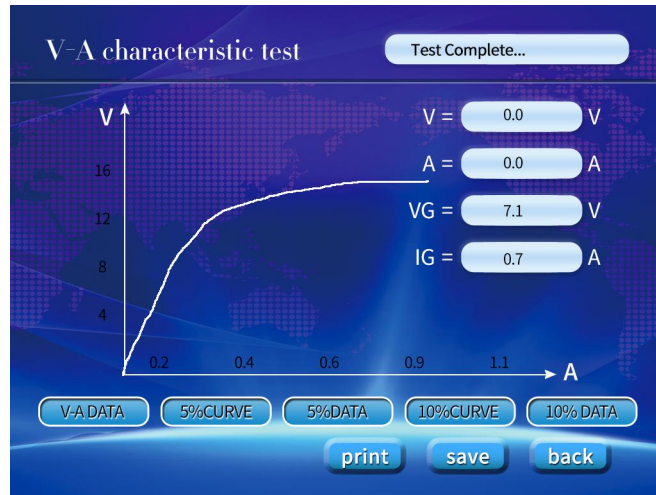

Figure 7

Print: click the print option with your finger, the printer will print the current volt ampere characteristic curve and the volt ampere characteristic data.

Save: click the save options with your fingers, you can save the current data and the volt ampere characteristic curve in the memory of the device.

Return: return to the first level menu interface.

Volt ampere characteristic data: after touching the click, will pop up the current volt ampere characteristic data sheet, on which is recorded volt ampere characteristic the voltage and current , as shown in figure 8.

NUM	VOLTAGE (V)	CURRENT (A)
1	0.0	0.000
2	9.3	0.027
3	16.8	0.054
4	21.0	0.075
5	26.2	0.102
6	29.5	0.129
7	31.9	0.153
8	33.7	0.176
9	36.0	0.211
10	36.9	0.229

Figure 8

5% error curve: after the touch Click to show 5% of the error curve, as shown in Figure 9.

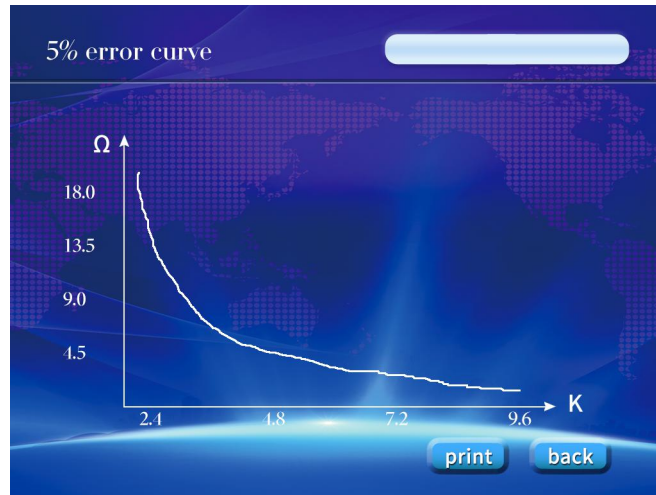

Figure 9

5% error data: touch Click to show 5% of the error data, as shown in Figure 10.

NUM	IMPEDANCE (Ω)	MULTIPLE (K)
41	1.1	9.4
42	1.1	9.4
43	1.0	10.0
44	1.0	10.6
45	1.0	10.7
46	0.9	11.4
47	0.9	11.4
48	0.9	12.4
49	0.0	0.0
50	0.0	0.0

Figure 10

**5% error curve test specification:**

(for the 5% error curve, the 10% error curve is similar)

Secondary load current transformer protection should meet the requirements of 5% error curve of current transformer, as long as current transformer two times the actual load is less than 5% error curve load allowed, at rated current ratio, current transformer qualified measurement error is less than 5%. The greater the two load, the more easily the current transformer core saturation, the current ratio of the allowable current is smaller. As shown in Figure 10 cases (measured CT 120/5 10P10level) the current ratio of 10 times, secondary load allowed is 1 ohms, which is larger than the ration 15VA of CT , $P=I^2 \cdot R$  is equal to 0.42 in Europe, then can judge the transformer qualification by the data.

10% error data curve: touch Click to show 10% of the error curve, as shown in figure 11.

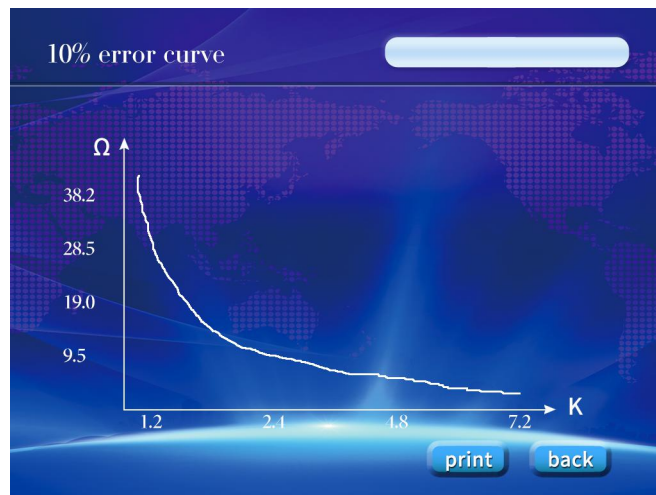

Figure 11

10% error data: touch Click to show 10% of the error data, as shown in Figure 12.

NUM	IMPEDANCE (Ω)	MULTIPLE (K)
1	23.1	0.3
2	21.3	0.4
3	18.9	0.4
4	17.2	0.5
5	16.4	0.5
6	15.2	0.6
7	14.4	0.6
8	13.4	0.7
9	12.2	0.8
10	11.5	0.9

Figure 12

**10% error curve is an important basic characteristic of the protective current transformer.**

The reaction of the relay protection device is a fault in the system, when a system fault and protection device act, a current of current transformer is usually higher than it in normal operation, therefore, the current transformer error will increase. In order to make the electric protection device can correctly reflect a system condition and the correct action, require current transformer ratio error is less than or equal to 10%, whether it is a current increase, or secondary times load impedance is increased, the result will cause

the current transformer induced electromotive force increases, thereby expanding the error. The 10% error curve is that the ratio error is 10%, the value of a current ( $I_1$ ) and rated current ( $I_2$ ) ratio ( $M = I_1 / I_2$ ) and relationship characteristic curve of secondary load impedance ( $Z_Y$ ). It can be understood as, under different a current times, in order to make the error of current transformer less than or equal to 10%, and the maximum secondary load impedance is allowable. In the actual work, the characteristic curve of CT was measured by the volt ampere characteristic, and then the 10% error curve of CT was drawn according to the characteristic curve of CT. According to current transformer 10% error curve shows comparing maximum allowable impedance  $Z_{Ymax}$  of secondary loop with actual impedance  $Z_L$  of the secondary loop, if  $Z_L < Z_{Ymax}$  that the current transformer is to meet the requirements of the 10% error.

(3) Refer to the records for inspection

Enter the data query interface, as shown in Figure 13



Figure 13

: Press this button to forward page-turning browsing test record, click the number of data which need to consult and carry out the tests records of inspection, printing and other operations.

 Press this button to back page browsing test record, click to view the number of data required to carry out the tests records of inspection, printing and other operations

**Note: if the 10% error does not meet the requirements, the general practice of**

the following points

- 1: increase the secondary the area of the cable (reducing the secondary impedance)
- 2: connect with the same type and same ratio current transformer (reducing transformer excitation current)
- 3: to use the winding of the higher volt-ampere characteristics (excitation impedance increases)
- 4: improve the current transformer ratio (increase excitation impedance)

#### 4、PT Volt Ampere Characteristic Test

In the main menu screen, click the voltage test with finger, that is, enter the PT test project to select menu (shown in Figure 14). Click with the finger whatever do any experiment, such as to cancel the current test project, you can directly return.

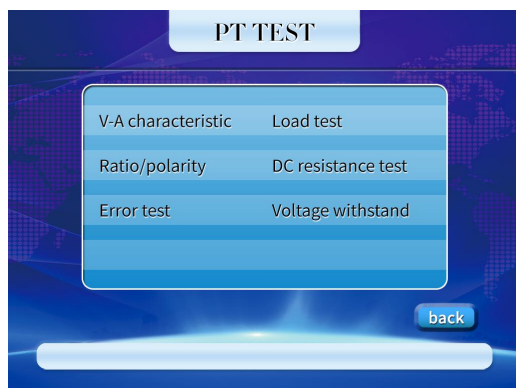

Figure 14

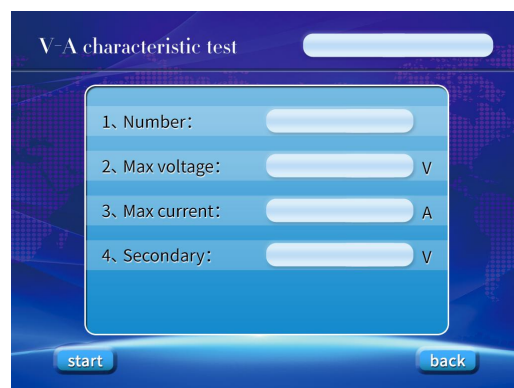

Figure 15

(1)The software interface of PT volt ampere characteristic test

Touch and click the volt ampere characteristics test, that is, enter the PT volt ampere characteristics test setup interface (Figure 15).

Interface parameter description:

Transformer number: specify a unique number for the current transformer.

The maximum output voltage: the maximum voltage of voltage transformer secondary side can bear, built-in booster voltage range is 0 ~ 200V.

Maximum output current: the maximum current of voltage transformer secondary side can bear, built-in booster current range is 0 ~ 25A.

PT secondary rated voltage: the rated voltage of the secondary side of the voltage transformer.

Start: press this button to start, enter the PT volt ampere characteristic test interface.

Return: press this key to return to the menu of the last interface.

Description: set the maximum output voltage and the maximum output current to protect the voltage transformer, in the test process, once the voltage or current exceeded the set value, the tester will automatically stop the boost.

Note 1: To test voltage transformer, the maximum output voltage do not set too high, so as to avoid the voltage transformer secondary side to step up and cause a voltage is too large, beyond the primary side of the electrical safety regulations.

Note 2: if doing PT volt ampere characteristic test continuously for a long time, should have a rest and cool for a while, lest the device overheating and burn out.

Note 3: the maximum output current of volt ampere characteristic set suggests does not exceed 3A, because the voltage transformer secondary side winding wire is relatively small, it is very dangerous to burn PT if the current is set too high.

(2) the operation of PT volt ampere characteristic test

Confirm the connection is correct, the firstly connect the main circuit output control switch (power switch), set the maximum output voltage, maximum output current, touch click start option, you can start the test.

a、Wiring test

Using the device to carry out a single test principle wiring diagram, as shown in Figure 16.

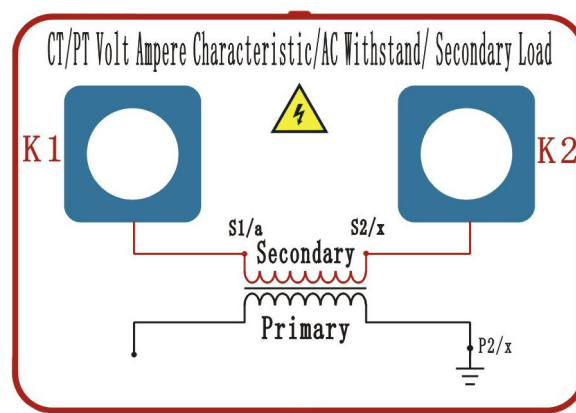

Figure 16

**Note 1:** do the volt ampere characteristic test, the terminals of polarity and ratio test do not

be connected with wire.

**Note 2:** do PT volt ampere characteristics test, should disconnect two wires of secondary winding of test with the original connection and can not be grounded, and broke off the other secondary winding

**Note 3:** the secondary low end of PT volt ampere characteristics connects to the ground, which prevents dangerous from a super high voltage

According to the experience: voltage of voltage transformer is set in 100V-150v, so you can set the 1A current on transformer inflection point, individual value is relatively large, the current can be set to 2A or 3A, set the 150V voltage, regardless of how the setting voltage can not exceed 200V (software limit protection transformer to avoid breakdown).

b、 Test method

According to the test wiring diagram, confirm it correct, connect the main circuit output control switch, in the setting of PT volt ampere characteristic test, touch click start, enter the curve interface of PT volt-ampere characteristic test(FIG. 17), the device gradually increase voltage ,current to test automatically according to the set voltage, current and voltage, display and record the voltage value and the current value and other parameters in the testing process.

During the test, the current and voltage on the top of the right is refreshed and displayed in real time, until the test is completed, the voltage regulator automatically return, or press return to stop test artificially.

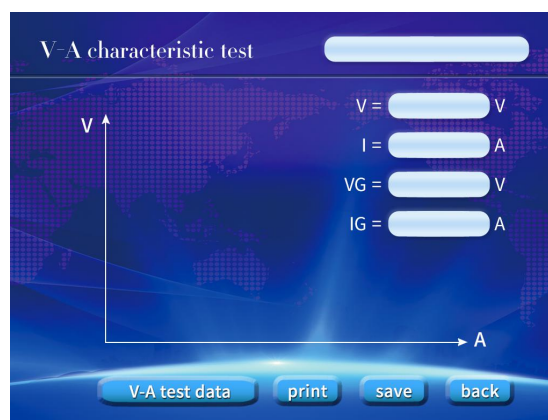

Figure 17

② Result operation description

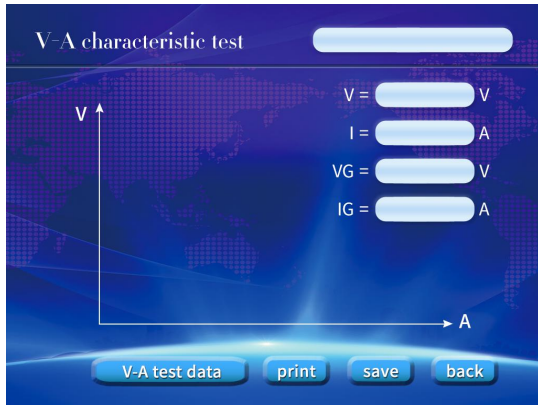

Figure 18

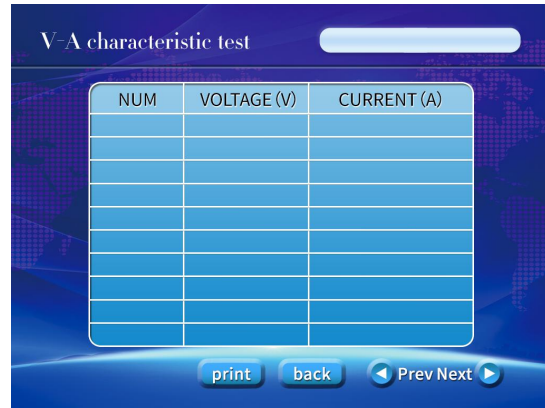

Figure 19

After the test, the screen shows the PT volt ampere characteristic test curve (shown in Figure 18). The interface functions as above.

Volt ampere characteristic data: after touch click, it will pop up the current volt ampere characteristic data sheet, record the voltage and current of the volt ampere characteristic above (Figure 19).

Print: click the print option with your finger, the printer will print the current volt ampere characteristic curve and the volt ampere characteristic data.

Save: Click to save, that is the current data and the volt ampere characteristic curve is stored in the memory of the device.

Return: return to the first level menu interface.

Stored test records in the data query, return to the main menu select data query, then it can be transferred out for check.

Enter the data query interface, as shown in Figure 20.



Figure 20

: Press this button to forward page-turning browsing test record, click the number of data which need to consult and carry out the tests records of inspection, printing and other operations.

: Press this button to back page browsing test record, click to view the number of data required to carry out the tests records of inspection, printing and other operations

## 5、 CT Ratio And Polarity Test

Enter the CT test content, select menu, touch selection ratio and polarity test, you can enter the CT ratio and polarity test setup interface, as shown in figure 21.

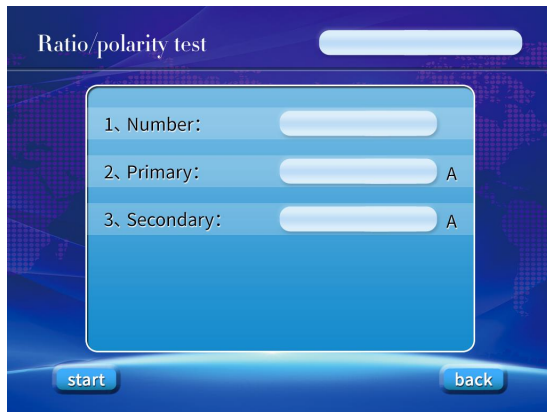

Figure 21

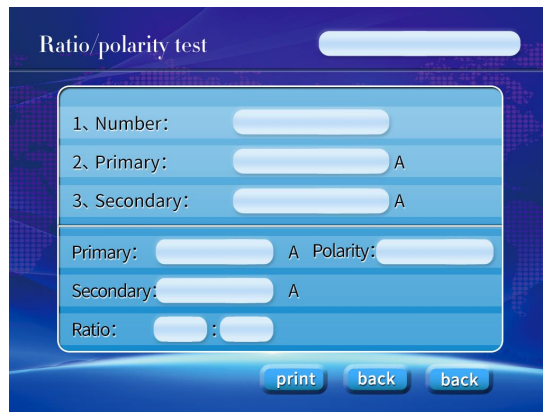

Figure 22

Interface parameter description:

Transformer number: input a unique number for the current transformer.

Primary side rated current, rated current of primary side of current transformer.

Secondary side rated current, rated current of the current transformer secondary side, 1 a or 5 a.

One side test current: in the variable ratio and polarity test, current imposed by transformer one side, built-in liters flow range (0 ~ 600) A.

Start: press this button to start, enter into CT ratio and polarity test results interface.

Return: touch to return directly to the first level menu.

### (2) Variable ratio polarity test instructions.

After confirming the right connection, firstly connect the main circuit ,output control switch, set the first test current, the secondary side rated current and other parameters, click on

the start option, you can start the test. If you press return, exit CT ratio. Polarity test interface .

3) Test

Test connection

Using the device to carry out the principle wiring diagram of a single test, as shown in figure 23.

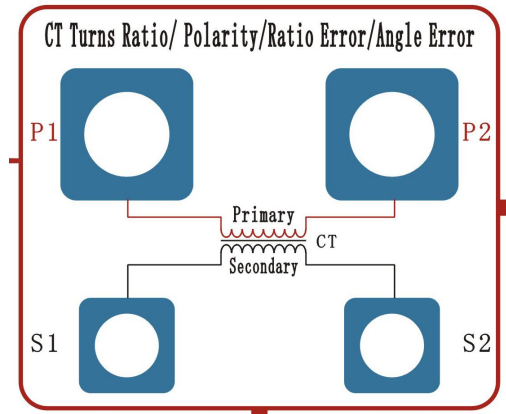

Figure 23

Note 1: ratio and polarity test, because of large one side the current , please try to use connection line which is wider and shorter, so as to avoid large a side resistance and cause current rise will not come up.

Note 2: when doing ratio and polarity test, please disconnect ground wire of two windings of CT test which is shorted circuited with the secondary windings of no test. Otherwise, the device may be damaged or the current can not be raised.

Note 3: if doing CT ratio and polarity test for many times for a long time, should have a rest and cool for a while, lest the device overheating and burn out.

Note 4: as do ratio test, to set a current and the secondary current according to the actual ratio size, such as the 600A.eg: 1000/1 current transformer, a set 1000A, secondary set of 1A, a current cannot be set very small such as a set of 50, this ratio is not accurate, two times the secondary current is too small and there is certainly no guarantee of accuracy.

② Test method

According to the test diagram, confirm the correct wiring, connect the main circuit, output control switch, the CT ratio and polarity test interface, touch select certain, enter

the CT ratio polarity test results interface as shown above.

After the test, the device output to the current transformer primary side of the AC current increasing, value of the current of the primary side current and the secondary side of the measured displayed on the screen. When the primary side current reaches some test point value, display results in the test results, the ratio and polarity.

One side of the current reach maximum set value or the secondary side current up to 5A (secondary side rated current of 5A) or 1A (secondary rated current is 1A), device automatically stop test, and calculate the last set of test results by the actual current and show the polarity.

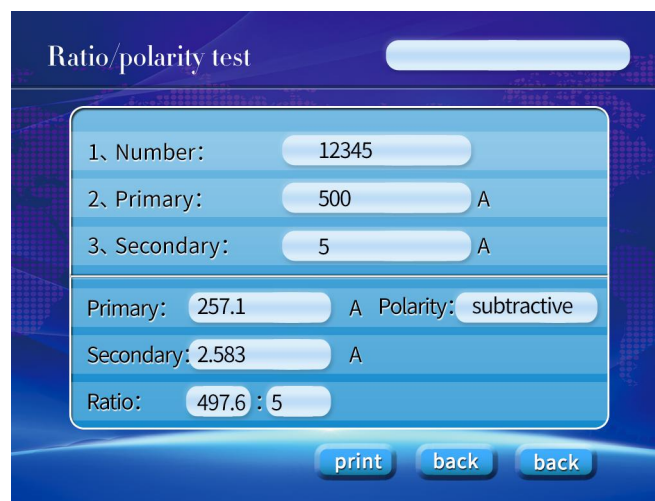

Figure 24

**Note:** due to too much the protection of CT species, the ratio range is very large (from 5:5 to 30000:1), so the measurement of different CT ratio, the current range is very large. In order to ensure the accuracy of measurement, the measurement should ensure that the secondary side current rises to 0.02 ~ 5.0A range.

(4) test results operation instructions

After the test, the test results of CT display screen ratio and polarity.

A side current: Variable ratio polarity test, the actual current imposed by one side current.

Secondary side current: Variable ratio polarity test, the actual current imposed by secondary side current.

Ratio: calculate the actual variable ratio by current of one side test and secondary side test.

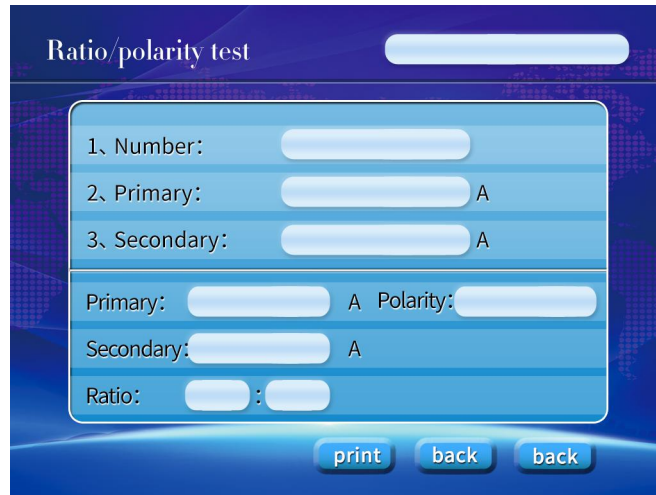

Figure 25

Polarity: The actual wiring polarity measured by ratio and polarity test.

The interface functions are as follows:

Print: Micro printer on the instrument print test interface ratio and results of polarity test.

Save: The test results of the current transformer are stored in the memory of the device.

Return: Return to the last menu.

## 6、PT Ratio And Polarity Test

Enter the PT test content, select menu, touch selection ratio and polarity test, you can enter the PT ratio and polarity test setup interface, as shown in figure 26.

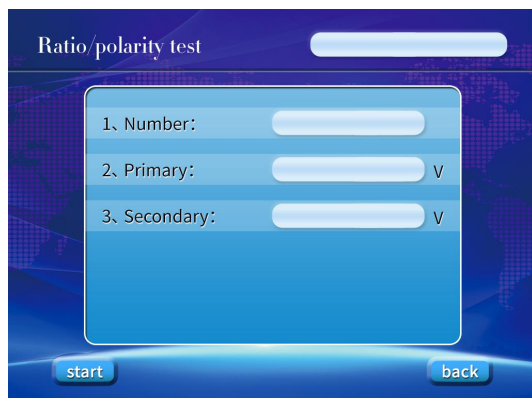

Figure 26



Figure 27

Interface parameter description:

Transformer number: input a unique number for the current transformer.

PT primary voltage: one side rated voltage of the voltage transformer. Range of

0-2000V.

PT secondary rated voltage: voltage transformer secondary side the rated voltage, 100V or 57.7V.

Start: press this button to start, enter PT ratio and polarity test interface

Return: touch to return directly to the first level menu.

(2) Variable polarity test instructions

After confirming the connection error, firstly connect the main circuit and output control switch, set the first voltage, the secondary rated voltage and other parameters, click on the start option, you can start the test. If you press return, exit PT variable polarity test interface.

(3) test

Test connection

Use the device to test the schematic wiring diagram, as shown in figure 28.

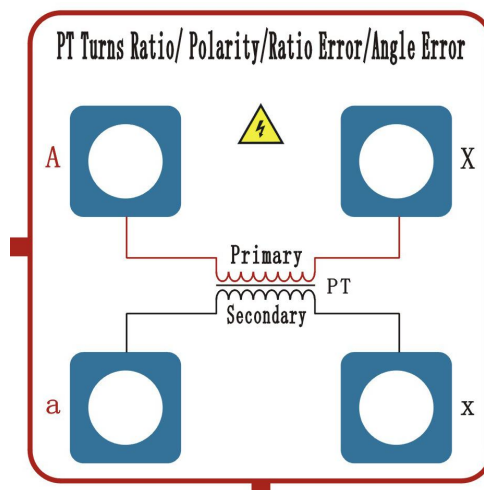

Figure 28

Note 1: as Variable polarity test, one side voltage is higher, especially for high variable ratio voltage transformer test such as 110KV, 220KV must ensure that the wiring is correct.

② Test method

According to the test connecting diagram, confirming the correct wiring diagram, connect the main circuit ,output control switch, the PT variable polarity test interface, touch selection, enter the PT variable polarity test results interface, as shown in figure 29.

After the test, the device output to the voltage transformer primary side AC voltage increasing, the primary side voltage and the secondary side voltage value displayed on the screen. When one side voltage reaches a certain voltage of test points, test results are shown the transformer in the test results, variable ratio and polarity.

The primary voltage reaches the maximum set value or the secondary side voltage up to 100V (secondary side rated voltage of 100V) or 57.7V (secondary rated voltage is 57.7V), device automatically stop test, and the actual measured current calculate test results and show the polarity.



Figure 29

(4) Test results operation instructions

After the test, screen display PT variable ratio and polarity test result.

A side voltage: the actual voltage imposed by one side when variable ratio polarity test.

Secondary side voltage: the actual voltage imposed by secondary side when variable ratio polarity test.

Variable ratio: when it is test, the actual variable ratio is calculated by actual voltage from one side and secondary side.

Polarity: the actual wiring polarity measured by variable ratio and polarity test.

Print: micro printer of the instrument print variable ratio of current test interface and polar test results.

Save: the test results of the current transformer are stored in the memory of the device.

Return: return to the last menu.

## 7、CT Secondary Load Test

(1) software interface of CT secondary load

Enter the CT test content, select menu, Touch Select fourth CT secondary load test column, touch Click to enter the settings interface, as shown in figure 30.

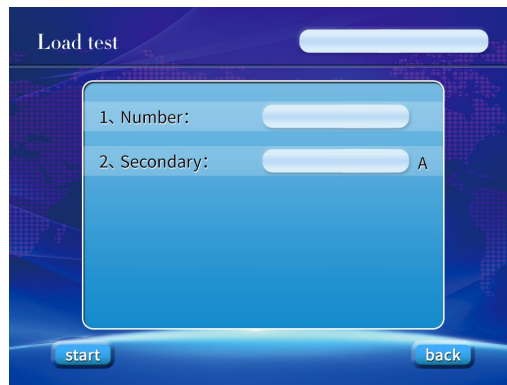

Figure 30

Interface parameters:

CT secondary rated current: the current transformer secondary rated current is generally 5A, or 1A.

(2) Secondary load test connection

The secondary load connection and the volt ampere characteristic has common one terminal, the panel K1, K2. Only two times connect, once disconnected.

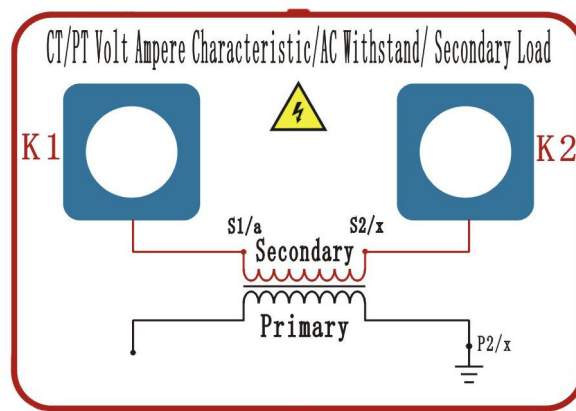

Figure 31

(3) CT secondary load test interface

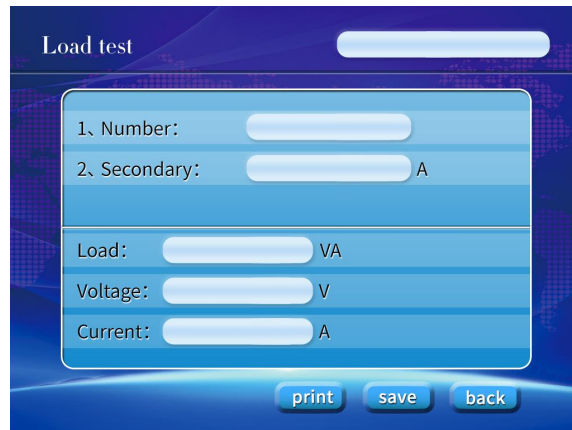

Figure 32

Test interface parameter description:

Secondary load: secondary load tested by current transformer

Output voltage: device current output voltage

Output current: the current of device output.

(4) test methods

After confirming that the connection is correct, put through the main circuit, output control switch, the secondary rated current of the transformer is set up, select ok, enter secondary load test interface.

After the beginning of the test, the device output to the current transformer secondary side current and voltage increasing, when the test results appear, the device automatically returns immediately, or human press the return button, that also can be terminated.

## 8、PT Secondary Load Test

(1) software interface of PT secondary load

Enter the PT test content, select menu, Touch Select fourth PT secondary load test column, touch Click to enter the settings interface, as shown in Figure 33.

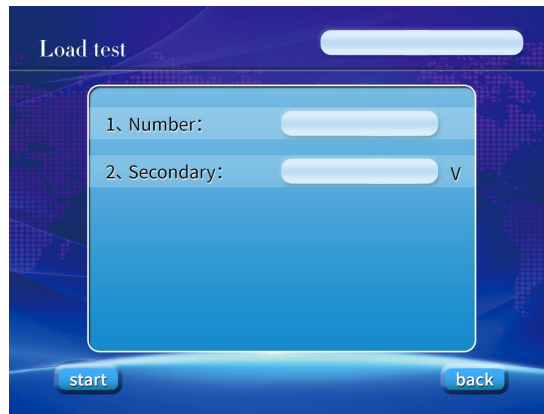

Figure 33

Set interface parameters:

PT secondary rated voltage: The current transformer secondary rated voltage is generally 100V, or 57.7V.

(2 Secondary load test connection

The secondary load connection and the volt ampere characteristic has common one terminal, the panel K1, K2. Only two times for connection, only one for disconnection.

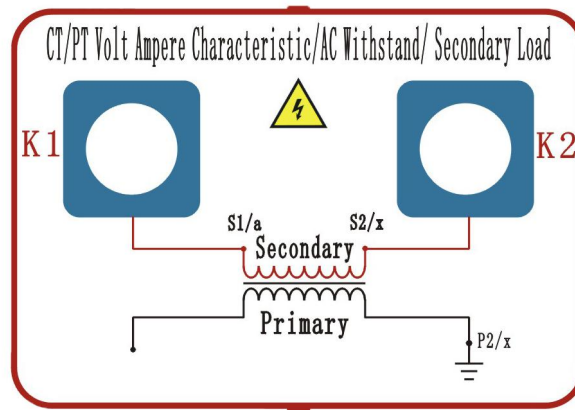

Figure 34

(3) PT secondary load test interface



Figure 35

Test interface parameter description:

Secondary load: secondary load tested by current transformer

Output voltage: device current output voltage

Output current: device output current.

(4) eTst methods

After confirming that the connection is correct, put through the main circuit, output control switch, the secondary rated current of the transformer is set up, select ok, enter secondary load test interface.

After the beginning of the test, the device output to the current transformer secondary side current and voltage increasing, when the test results appear, the device automatically returns immediately, or human press the return button, that also can be terminated.

## 9、CT Secondary DC Resistance Measurement

(1) software interface of CT secondary side DC resistance.

Enter the CT test content, select menu, Touch Select fifth CT secondary DC resistance test, and then press the ok button to enter the test interface.

(2) CT secondary side DC resistance operation instructions.

① Test connection

Elementary wiring diagram of CT secondary side dc resistance measurement.

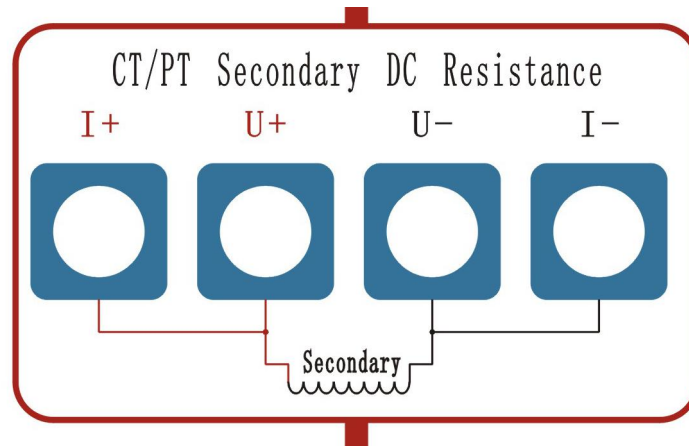

Figure 36

②Test method

Confirm the connection is correct, the firstly put through the main circuit, output control switch, and then set the measured CT transformer number.

After the start of the test, the device will generally be able to test the DC resistance of the current transformer in a very short time (shown in Figure 37).

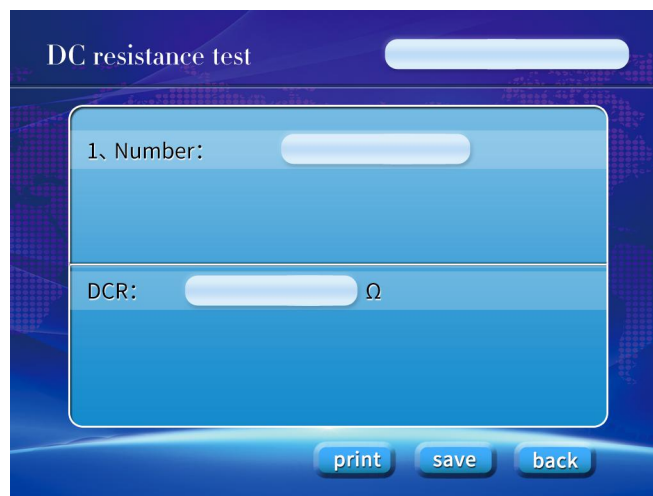

Figure 37

## 10、 PT Secondary DC Resistance Measurement

(1) software interface of PT secondary side DC resistance

Enter the PT test content, select menu, Touch Select fifth PT secondary DC resistance test, and then press the ok button to enter the test interface.

(2) PT secondary side DC resistance operation instructions

①Test connection

Elementary wiring diagram PT secondary side dc resistance measurement as show

n in figure 38.

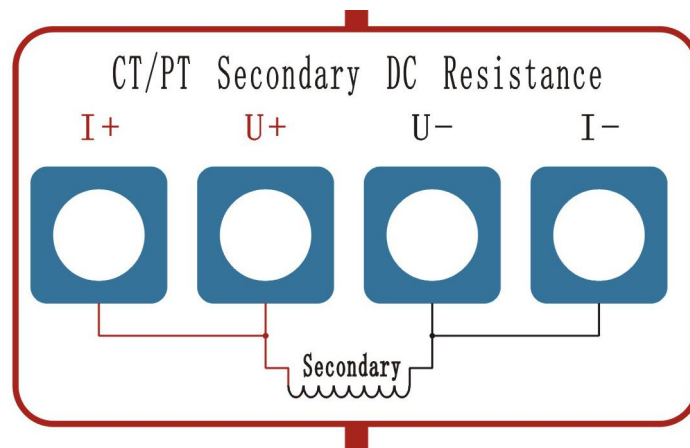

Figure 38

②Test method

Confirm the connection is correct, the firstly put through the main circuit, output control switch, and then set the measured CT transformer number.

After the start of the test, the device will generally be able to test the DC resistance of the current transformer in a very short time (shown in Figure 39).

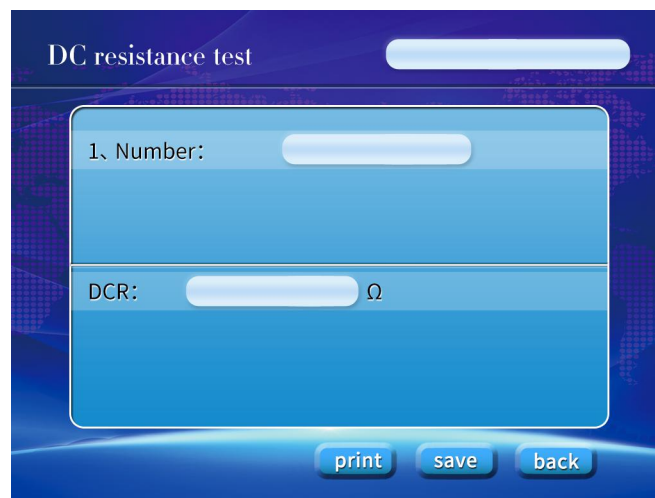

Figure 39

## 11、 CT Transformer Secondary AC Voltage Test

(1) The software interface of the AC voltage withstand test of the secondary winding

Enter the CT test content ,select menu ,select the sixth item CT AC voltage test, that is, to enter the secondary winding AC voltage test interface, as shown in figure 40.



Figure 40

**Interface parameter description:**

Maximum output voltage: in the secondary winding AC voltage test, voltage imposed by the transformer secondary side and the outer shell, Pressure range of 0 ~ 2000V.

keeping time: the voltage between the secondary side of the transformer and outer shell is raised to the set value, the duration of the voltage can be arbitrarily set, the device does not limit it.

(2) Operation instructions

Test connection

Note: in the CT secondary winding AC voltage withstand test, it is necessary to ensure that the CT shell and the earth has a good insulation, so as not to damage the device. As shown in figure 41.

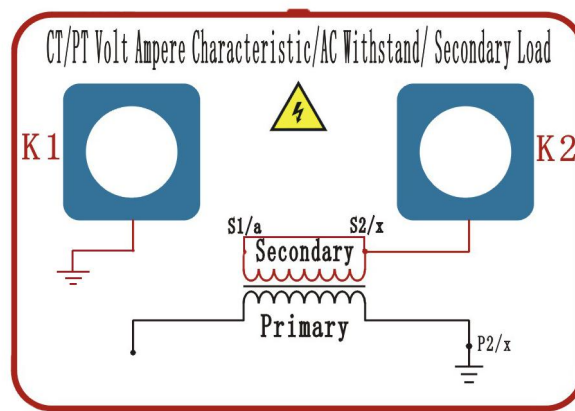

Figure 41

② Test method

Confirm the connection is correct, put through the main circuit ,output control switch, set parameters, press the start, that is, enter into the transformer secondary winding AC voltage withstand test interface (shown in Figure 42).



Figure 42

After the start of the test, the AC voltage is increasing between the outer shell and output to transformer secondary side, the output voltage bar on the screen display real-time value. When the voltage reaches the set value of the test voltage, the device reads the system time and automatically records the time. When the time achieve the set test time, the device automatically stop test, the regulator automatically returns and in the test status bar display "complete", said the pressure test go through.

## 12、 PT Transformer Secondary AC Voltage Test

(1) the software interface of the AC voltage withstand test of the secondary winding

Enter the PT test content , select menu , select the sixth item PT AC voltage test, that is, to enter the secondary winding AC voltage test interface, as shown in figure 43.



Figure 43

Interface parameter description:

Maximum output voltage: in the secondary winding AC voltage test, voltage required between the transformer secondary side and the outer shell , the boost range of 0 ~ 2000V.

Holding time: the voltage between the secondary side of the transformer and the outer shell is raised to the set value, the duration of the voltage is 0 ~ 600s.

(2) test wiring

PT AC withstand voltage test wiring is the same with CT, as shown in figure 44.

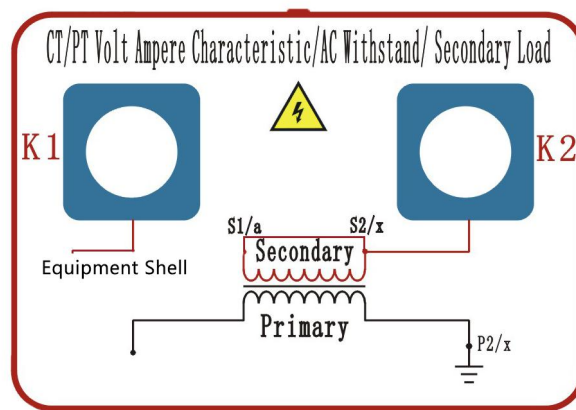

Figure 44

Note: doing PT AC withstand voltage, due to secondary side voltage, at this time a voltage is very high, especially 110KV, 220 KV of the voltage transformer, in order to the safety , the low end of PT must be of the ground.

(3) Test methods

Confirm the connection is correct, put through the main circuit ,output control switch, set parameters, press the start, that is, enter into the transformer secondary winding AC voltage withstand test interface, as shown in figure 45.



Figure 45

After the start of the test, the AC voltage is increasing between the outer shell and output to transformer secondary side, the output voltage bar on the screen display real-time value. When the voltage reaches the set value of the test voltage, the device reads the system time and automatically records the time. When the time achieve the set test time, the device automatically stop test, the regulator automatically returns and in the test status bar display "complete", said the pressure test go through

### 13、 CT Ratio Error And Angle Error Test

(1) CT ratio error and angle error test connection

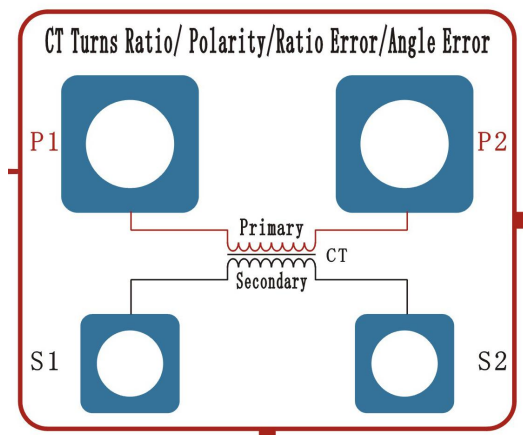

Figure 46

(2) CT ratio error and angle error test specification

In the CT ratio error and angle error settings interface after parameter setting, click OK, the instrument automatically jump to this setup, the current device will gradually increase the CT primary side, and in the error data table shows the current transformer ratio error and angle error, as shown in figure 47.



Figure 47

Primary side current: the actual current imposed by one side when variable ratio polarity test.

Secondary side current: the actual current imposed by secondary side when variable ratio polarity test.

Print: micro printer of the instrument print variable ratio of current test interface and polar test results.

Save: the test results of the current transformer are stored in the memory of the device.

Return: return to the last menu

(3) check the test records of storage

Enter the data query interface, as shown in figure 48.



Figure 48

: Press this button to forward page-turning browsing test record, click the number of data which need to consult and carry out the tests records of inspection, printing and other operations.

 Press this button to back page browsing test record, click to view the number of data required to carry out the tests records of inspection, printing and other operations.

## 14、PT Ratio Error And Angle Error Test

(1) PT ratio error and angle error test connection

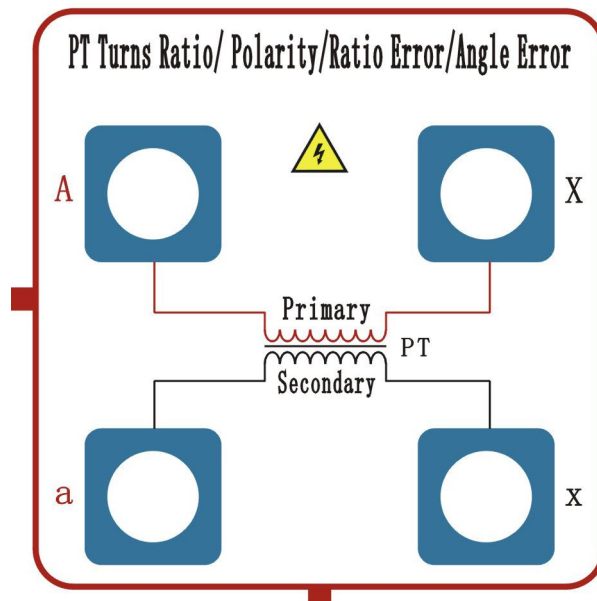

Figure 49

(2) PT ratio error and angle error test specification

Parameter is Settled in the PT ratio error and angle error Settings interface, click o k, the instrument automatically jump to the interface design, device will gradually in crease the voltage of PT primary side, and will show ratio error and angle error of transformer in the error data form, as shown in figure 50.

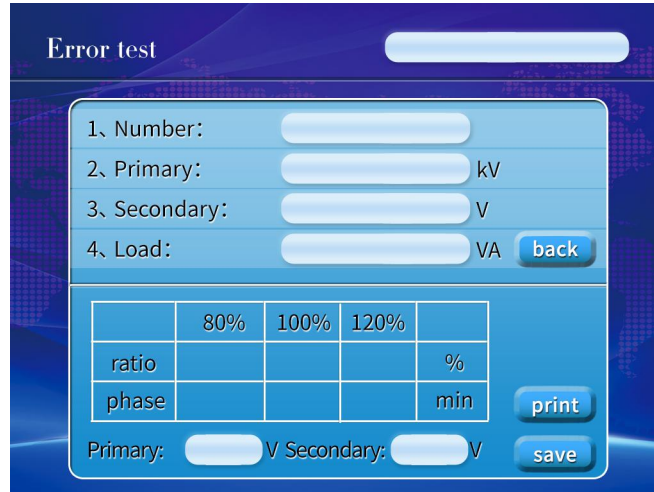

Figure 50

Primary voltage: the actual voltage imposed by the primary side as ratio error and angle error test.

Secondary voltage: actual voltage measured by the secondary side as ratio error and angle error test

Print: By the instrument's own miniature printer to print the current test results in the interface of the test.

Save: the test results of the current voltage transformer are stored in the memory of the device.

Return: return to the last menu.

(3) Check the test record of storage

Enter the data query interface, as shown in Figure 51.



Figure 51

: Press this button to forward page-turning browsing test record, click the number of data which need to consult and carry out the tests records of inspection, printing and other operations.

: Press this button to back page browsing test record, click to view the number of data required to carry out the tests records of inspection, printing and other operations.

## 15、 CT Primary Flow Test

(1) CT a flow software interface

Enter the CT test content ,select menu to select the seventh item CT a pass flow test, that is, to enter the CT a pass flow test interface, as shown in figure 52.

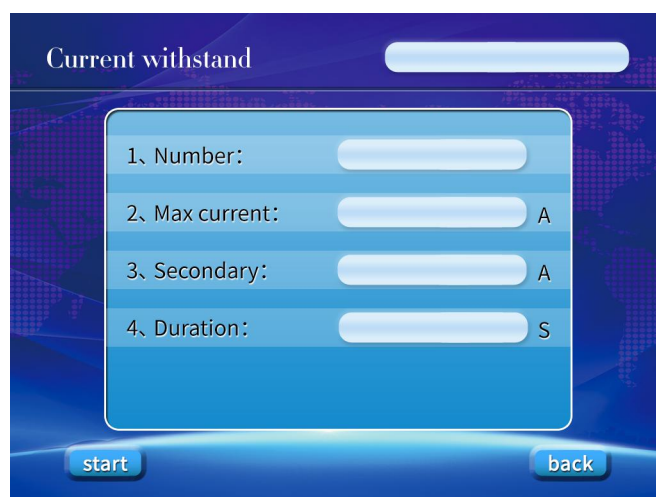

Figure 52

(2) Interface parameter description:

The maximum output current: In current transformer flow test, current imposed by t

he transformer, the range of 0-1000 - a.

CT secondary rated current: current transformer secondary rated current is generally 5A, or 1A.

Hold time: current imposed by transformer reach the set value, the duration of the current, (0 ~ 200 a: maximum maintain 5 minutes; more than 200 a ~ 300 a: keep 2 minutes, larger than 300 a: maximum stay for 5 seconds.

(3) Operation instructions

1).Test connection

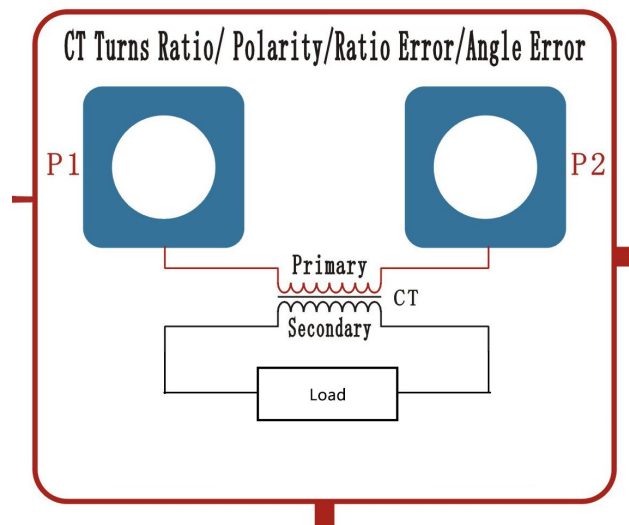

Figure 53

**Note:** In a flow test, CT a wire connect closely, otherwise it will lead to terminal or conductor heating.

**Test method**

After confirming the right connection, put through the main circuit output control switch, the parameters are set, press start, that is, enter into current transformer a pass flow test ,as shown in Figure 54.

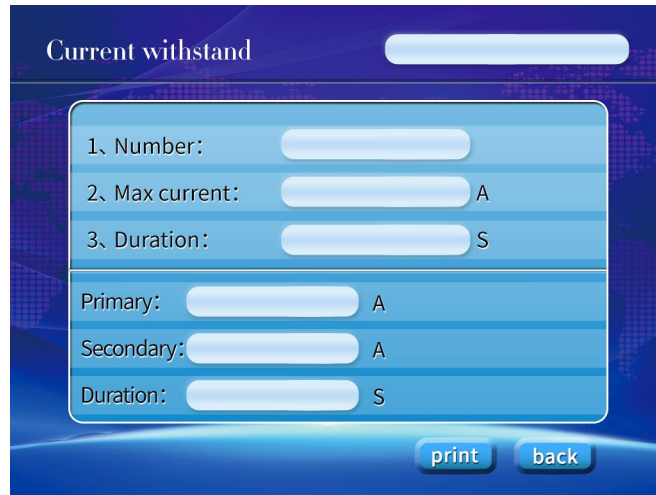

Figure 54

After the test, the device output to the transformer primary side of the current increase, in the screen once the current bar display real-time value. When the current reaches the set value of the test current, the device reads the system time and automatically records the time. When the time achieve the set test time, the device automatically stops the test, the regulator automatically returns and displays the "complete" in the test status bar ,that is pass.

## 16、 U Disk Transmission

Insert the U disc to USB interface on the device panel, after confirmation, touch selection began to save, all test is recorded in memory devices (including CT volt ampere characteristics, PT volt ampere characteristics and CT ratio and polarity of historical test data) transferred to U disk, the original record is still retained, as shown in Figure 55 shown.

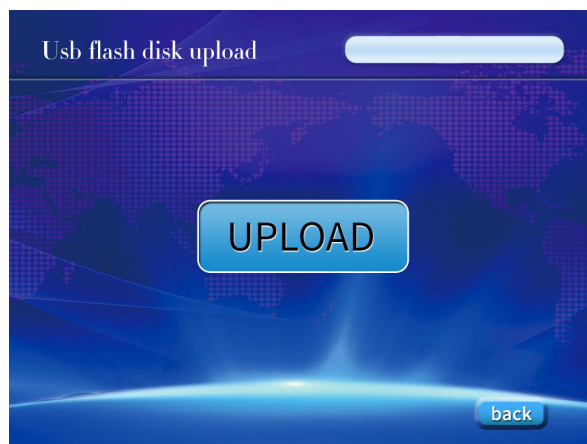

Figure 55

When saving, the upper right corner will prompt detection of U disk, is saving the status and so on prompt. Transferred to U disk,you can see the file as shown in the U disk, all the data is saved in the TXT file. It is easy for user to extract and backup (U Max capacity 8GB).

## 17、 Clock Settings

Enter the main menu, touch the select clock set to enter the system time operation interface (shown in Figure 56). Select setup time, you can enter the system time settings interface. In this interface, you can change the annual, monthly, daily and real-time clock.



Figure 56

## 18、 Factory Settings

Factory Settings section is used for precision and function of debugging device before manufacture, it is not open to the user.

## IV. Fault Maintenance

If there are some abnormal situations in the process of device use, please follow these steps to deal with:

- 1, if the voltage output is not normal, such as the amplitude is too low, or even close to zero, please check the panel air switch is closed or AC power supply is connected.
- 2, if the boot without any reaction, the power indicator and display do not light, please check the insurance(20A) is disconnected on the bottom of left corner of the power supply socket
- 3, If it is internal fault, please contact in my company, my company will be

resolved as soon as possible.

## V. Scroll Printer Installation

Install the roll

- 1, disconnect the power supply, the OPEN button of panel is pressed in the front of printer, cover will pop-up
- 2, pinch the ends of the telescopic paper shaft, the paper will be removed from the printer.
- 3, the new paper is placed in the paper box, pay attention to the relatively smooth face down (thermal printing paper sensor surface).
- 4, close the cover, the installation is complete.

## VI. Common Fault Handling And Usage

1, If the device has no current and voltage output, please check the insurance of the panel power outlet inside (20A) is disconnected. If it is, the single stranded copper wire with the same thickness has been used for welding. Of course, it is best to replace insurance of the same model.

2, Do ratio test, if one side of a current rise, no current secondary side current, Multimeter measuring instrument test CT ratio secondary side, so secondary side is pathways: 1) please check whether the CT secondary side open circuit; (2) please check whether phase of the secondary side wiring is the same with one side .

3, Host each function module can save up to 50 sets of data, the instrument without power ,data can be permanently stored in the data, in order not to affect your normal work, please print or upload data in a timely manner to save the computer.

4, Currently on the market , other manufacturers will add a core function of demagnetization in the device, this function is in fact secondary applying an AC voltage of CT, and then return ,that is demagnetization. In fact, it is the volt ampere characteristics of the test, you can check relevant information.

5.1000A models, Inside the wiring package will configure four high-current conductor, respectively, two 50 square, two 35 square root, less than 600 a, you just need two lines of 50 square to normally rise, higher than 600 a, need to another group of wires 35 square in parallel using.

## VII. Packing List

No.	Item	Qty
1	Main engine	1
2	Primary red large current wire with clip	1
3	Primary black large current wire with clip	1
4	Secondary test lead	4
5	Clip	1
6	Fuse pipe	3
7	Ground lead	1
8	Power line	1
9	printer paper	2